

27.07.2018

**PCN****Mittelfrequenz-Schweißen bei der EM-Serie von EPCOS 2-Elektroden-Ableitern**

Das Mittelfrequenz (MF)-Schweißen wurde für die EM-Serien von EPCOS 2-Elektroden-Ableitern, die in Xiaogan, China, hergestellt werden, qualifiziert und intern freigegeben. Statt Eisen-Nickel (FeNi) wird für das Elektrodenmaterial künftig Kupfer (Cu) verwendet. Die Abmessungen der Bauelemente bleiben mit Ausnahme einer geringfügigen Änderung der Kalotte der Außenelektroden unverändert. Das Werk in Xiaogan hat die MF-Schweiß-technologie für andere Produkte bereits 2010 eingeführt.

**Betroffene Produkte** siehe Anlage

Geplante Einführung: 5. November 2018

Alle elektrischen und mechanischen Eigenschaften sowie die Typenbezeichnungen und Lieferzeiten bleiben unverändert. Eine Qualifizierung entsprechend unserer internen Green-light Release Guidelines wurde erfolgreich durchgeführt.

**Anlage** PCN (ID No. PPD4/T123)  
Betroffene Produkte  
Vergleich der Designs vor und nach Einführung des MF-Schweißens

**Kontakt** Wong Huan Chee, PPD AB PM, Johor Bahru

**Kunden wenden sich bei Fragen bitte direkt an ihren Ansprechpartner im Vertrieb.**

## Product / Process Change Notification

<b>1. ID No.:</b> PPD4/ T123		<b>2. Date of announcement:</b> July 27, 2018	
<b>3. Product / product group:</b> EM series of EPCOS 2-electrode surge arresters	<b>Old ordering code:</b> See annex	<b>New ordering code:</b> N/A	<b>Customer part number:</b> N/A
<b>4. Description of change:</b> Middle frequency (MF) welding has now been qualified and internally approved for the EM series of EPCOS 2-electrode surge arresters manufactured in the Xiaogan, China, plant. Copper (Cu) will be used as the base electrode material instead of iron-nickel (FeNi). The dimensions of the components remain unchanged with the exception of very minor modifications to the calotte of the outer electrodes. The details of the change and the affected products are listed in the annex.			
<b>5. Effect on the product or for the customer (benefit, quality, specification, lead time):</b> The type designations and delivery times remain unchanged. All electrical and mechanical characteristics are unchanged.			
<b>6. Quality assurance measures / risk assessment:</b> The qualification is in accordance to ISO/TS 16949 quality procedure. The investigations for internal release showed no effects on the mechanical characteristics as a consequence of the change described in item 4. The established control plans will consequently not be changed. All quality assurance measures will be maintained. Samples are available on request.			
<b>7. Scheduled date of change:</b> November 5, 2018			
<b>8. Estimated date of first delivery of changed product:</b> November 5, 2018 If EPCOS does not receive notification to the contrary within a period of 10 weeks, EPCOS assumes that the customer agrees to the change. For an interim period we cannot rule out that old as well as new products will be shipped.			
Quality Management		Signature	
Name Markus Weiglhofer		signed Weiglhofer	
Product Marketing		Signature	
Name Wong Huan Chee		signed Wong	
Tel. +607 3566 666			
Email huanchee.wong@epcos.com			

<b>Customer feedback</b>	
Customer acknowledgement	Signature

**Annex to UPtoDATE 180727AB1 and PCN PPD4/T123 of July 27, 2018 /  
Additional MF welding technology for EM surge arresters**

**Affected products**

Type	Ordering code
EM90X	B88069X0190T102
EM90X	B88069X0190S102
EM90X	B88169X2272S102
EM90X6T7	B88069X2333A103
EM90X6T7	B88069X2333A802
EM90XG	B88069X0190T502
EM90XG	B88169X2272T502
EM150X	B88069X5921S102
EM230X	B88069X0900T502
EM230X	B88069X0900S102
EM230X	B88069X0900T103
EM230X	B88169X2281S102
EM230XB5	B88069X6601B502
EM230XHC	B88069X4303S102
EM230XHC	B88069X4303T502
EM230XN	B88069X5351C253
EM230XNW	B88169X2066B502
EM300X	B88069X0380S102
EM300X	B88069X0380T502
EM300X	B88069X0800S102
EM300X	B88069X0800T502
EM300XC	B88069X2650B502
EM300XN	B88069X0450C253
EM300XS	B88069X0178S102
EM300XS	B88069X1780S102
EM300XS	B88069X1780T502
EM300XSE	B88069X4170B502
EM300XSN	B88069X0390C253
EM300XSNG	B88069X2740T103
EM300XSP	B88069X4270B502
EM300XSP6	B88069X4280B502
EM350X	B88069X0590S102
EM350X	B88169X2247S102

Type	Ordering code
EM350X6G	B88069X5711S102
EM350X6G	B88069X5711T502
EM350X6T7	B88069X2343A802
EM350XB6	B88069X0160B502
EM350XB6	B88069X0160C103
EM350XB6G	B88069X0990T103
EM350XC2	B88069X4281B502
EM350XG	B88069X0980T502
EM350XS	B88069X6271S102
EM350XS	B88069X6271T502
EM350XST10	B88069X3581B502
EM350XT	B88069X5990B502
EM400X	B88069X9751T103
EM400X	B88069X0200S102
EM400XG	B88069X0820T502
EM420X	B88069X6090S102
EM420X	B88169X2290S102
EM420XS	B88069X4931S102
EM450X	B88069X7131S102
EM470XS	B88069X7091S102
EM470XS	B88069X7091T502
EM500X	B88069X2780S102
EM500X	B88069X4093S102
EM500X	B88069X4351S102
EM500X	B88169X2254S102
EM500X6B6	B88069X1773B252
EM500X6B8	B88069X2823B252
EM500X6T7	B88069X1783A802
EM500XG	B88069X2810T502
EM550X	B88069X2910S102
EM600X	B88069X2593T502
EM62-A400XT5	B88069X8771A103
EM62-A400XT5	B88069X8771T103
EM63-C230XCA	B88069X7271S102

## Comparison between current and MF welding design

Drawing of current welding design:

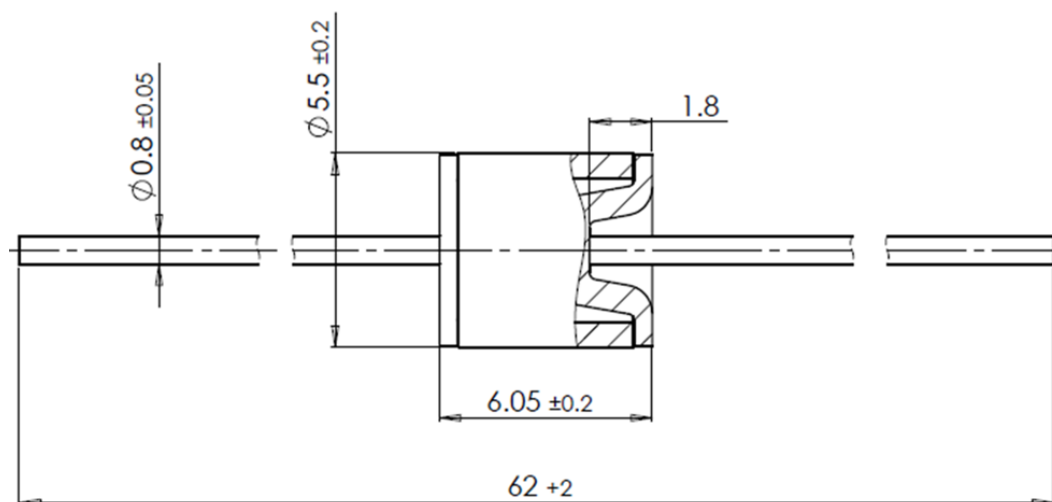

Drawing of new MF welding design:

