

Transient Voltage Suppressor

Features

- IEC 61000-4-2(ESD) $\pm 30\text{KV}$ (air), $\pm 30\text{KV}$ (contact)
- IEC61000-4-5(Lightning) 100A (8/20 μS)
- 2000W peak pulse power (8/20 μS)
- Low operating voltage and low clamping
- Intergrated structure saves board space and increases reliability
- Moisture sensitivity level: Level 3
- SOP8 package

Exterior



SOP-8

Application Information

- 10/100M Ethernet

Package (top view)



Agency Approvals

Icon	Description
RoHS	Compliance with 2011/65/EU
HF	Compliance with IEC61249-2-21:2003
	Mean lead free

Schematic Symbol

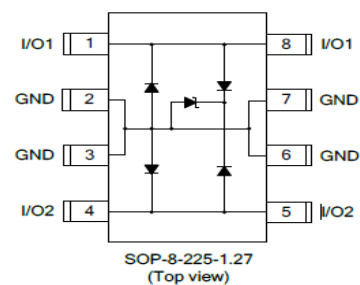

Part Number and Electrical Parameter

Part Number	$I_{\text{DRM}}@V_{\text{DRM}}$		$V_{\text{BR}}@I_{\text{R}}$		$V_{\text{c}}@I_{\text{pp}}^{\text{①}}$		$V_{\text{c}}@I_{\text{pp}}^{\text{①}}$		$C_{\text{o}}^{\text{②}}$	$C_{\text{o}}^{\text{③}}$
	μA	V	V	mA	V	A	V	A	pF	pF
	MAX		MIN		MAX		MAX		MAX	MAX
BV-P806Z2	25	6.0	6.8	1	14	25	20	100	20	10

Absolute maximum ratings measured at $T = 25^{\circ}\text{C}$ RH = 45%-75% (unless otherwise noted).

① Surge Waveform: 8/20 μ S, I/O to GND.

② Off-state capacitance is measured in $V_{\text{DC}}=0\text{V}$, $f=1\text{MHz}$, any I/O to GND.

③ Off-state capacitance is measured in $V_{\text{DC}}=0\text{V}$, $f=1\text{MHz}$, any I/O to I/O.

Transient Voltage Suppressor

Part Numbering System

Mark

BV P8 06 Z 2
(1) (2) (3) (4) (5)

- (1) Bencent Transient Voltage Suppressor
- (2) Package:SOP-8
- (3) Stand-off Voltage: 6V
- (4)Normal Capacitance
- (5)2 channel

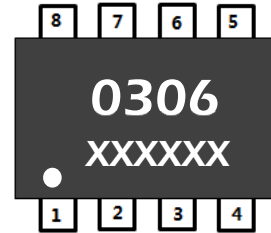

0306: Part Number
XXXXXX: Trace code

V-I Curve

Parameters	Definition
V_C	Clamping Voltage
I_{PP}	Surge Waveform 8/20 μ s
V_{DRM}	Stand-off Voltage
V_{BR}	Breakdown Voltage
I_{DRM}	Reverse Leakage Current
I_R	Test Current
P_{pp}	Peak Pulse Power Dissipation

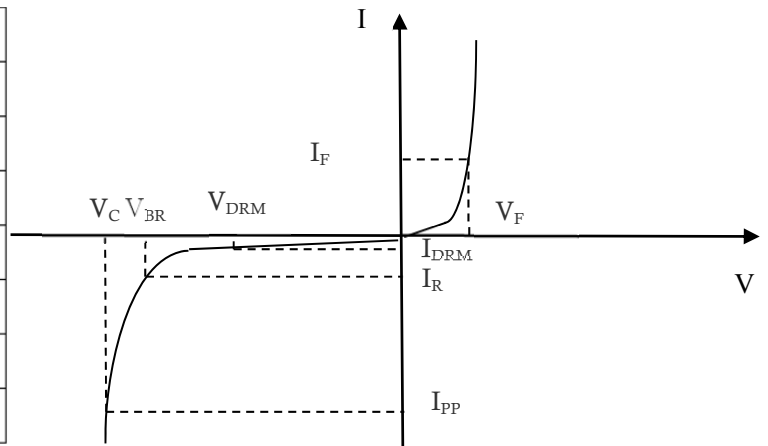

Thermal Considerations

symbol	Parameter	Value	Unit
T_j	Operating Junction Temperature Range	-55 to +125	°C
T_s	Storage Temperature Range	-55 to +150	°C

Environmental Characteristics

Testing items	Technical standards
High temperature Reverse Bias Test	Temperature: 125 \pm 3°C Bias=80% V_{DRM} . Time:96H
High Temperature Storage Test	Temperature: 150°C Time:168H
High-low Temperature Cycle test	Temperature: From -40°C to125°C Dwell time : 30min,100cycles
High Temperature &High Humidity Test	Temperature: 85°C Humidity:85% Time:168H
Pressure cooker Test	Temperature: 121°C, 2atm. Humidity:100% Time:24H
Resistance of soldering heat	Temperature: 260 \pm 5°C Time of dip soldering: 10s, 3times

Note: The above testing items can be specified by customer's special request

Transient Voltage Suppressor

Version: A0 2016-11-14

Product Dimensions

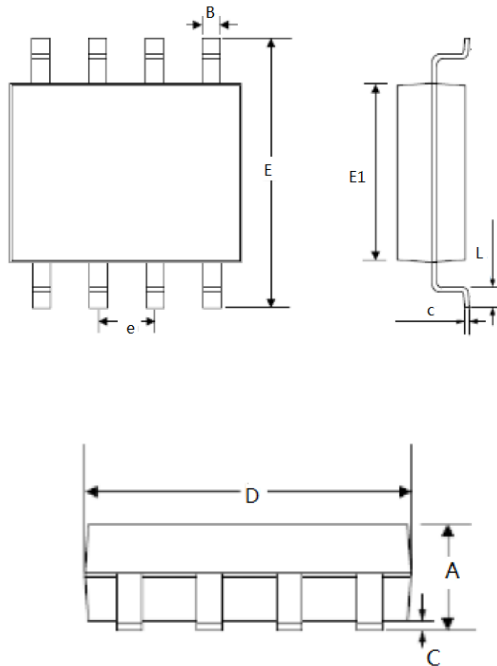

REF	mm	inch
A	<1.75	<0.0689
D	5.00±0.50	0.1969±0.0197
C	0.15±0.10	0.0059±0.0039
B	0.43±0.10	0.0173±0.0020
e	1.27±0.10	0.0500±0.0039
E	6.00±0.40	0.2362±0.0157
E1	3.90±0.30	0.1535±0.0118
c	0.20±0.05	0.0079±0.0020
L	0.30-1.27	0.0118±0.0500

Reflow Profile

Reflow Condition		Pb-Free Assembly
Pre Heat	Temperature Min.	+150°C
	Temperature Max.	+200°C
	Time(Min to Max)	60 – 180 secs.
Average ramp up rate(Liquidus Temp(T_L) to peak)		3°C/sec. Max.
Ts(max) to T_L - Ramp-up Rate		3°C/sec. Max.
Reflow	- Temperature (T_L) (Liquidus)	+217°C
	- Temperature (T_L)	60 – 150 secs.
Peak Temp (T_P)		+(260+0/-5)°C
Time within 5°C of actual Peak Temp (T_P)		30 secs.
Ramp-down Rate		6°C/sec. Max.
Time 25°C to peak Temp (T_P)		8 min. Max.
Do not exceed		+260°C

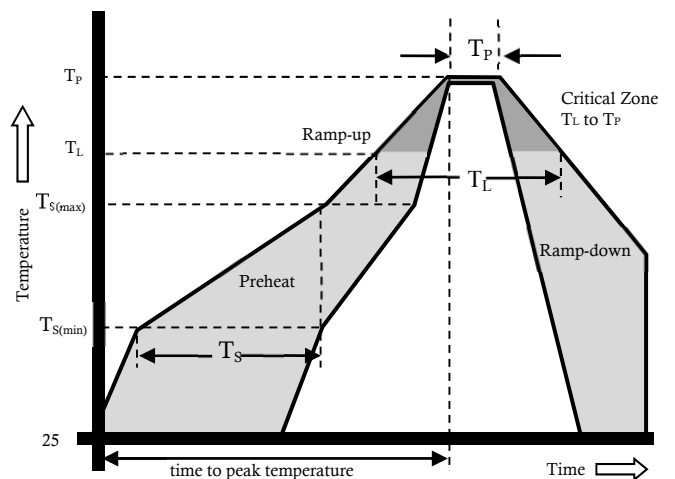

Transient Voltage Suppressor

Package Reel Information

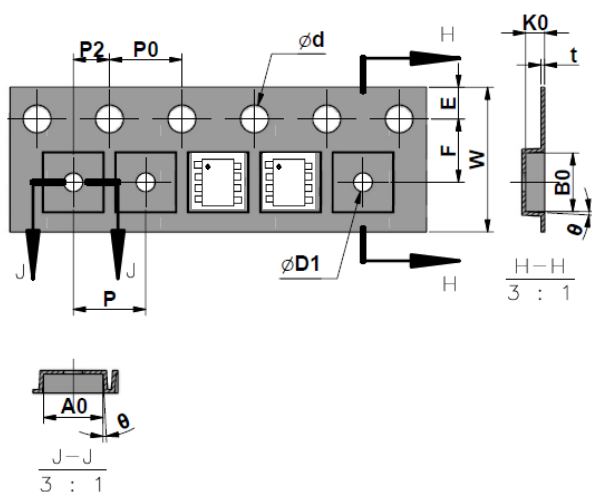

REF	mm	inch
A0	6.70 ± 0.25	0.2638 ± 0.0098
B0	5.20 ± 0.25	0.2047 ± 0.0098
d	1.55 ± 0.10	0.0610 ± 0.0039
E	1.75 ± 0.10	0.0689 ± 0.0039
F	5.50 ± 0.20	0.2165 ± 0.0079
P2	2.00 ± 0.20	0.0787 ± 0.0079
P0	4.00 ± 0.20	0.1575 ± 0.0079
P	8.00 ± 0.20	0.3150 ± 0.0079
W	12.00 ± 0.20	0.4724 ± 0.0079

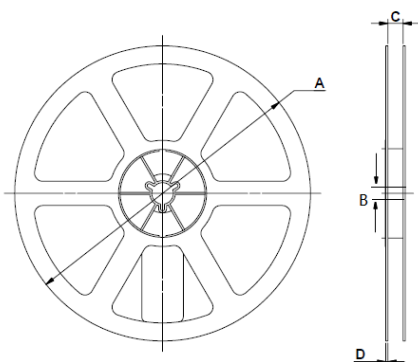

A	330.00 TYP	13.00TYP
B	13.00 ± 0.50	0.5118 ± 0.0197
C	12.50 ± 1.00	0.4921 ± 0.0394
D	2.00 ± 0.20	0.0787 ± 0.0079

OUTLINE	REEL (PCS)	PER CARTON (PCS)	REEL DIAMETERS (mm)	CARTON SIZE(mm)		
				L	W	H
TAPING	3000	24000	330	360	360	380